

MITSUBISHI

A/D Converter module type A1S64AD

User's Manual (Hardware)

Thank you for buying the Mitsubishi general-purpose programmable controller MELSEC-A Series

Prior to use, please read both this manual and detailed manual thoroughly and familiarize yourself with the product.



MODEL	A1S64AD(H/W)-U-E
MODEL CODE	13JE46
IB(NA)-66485-E(1112)MEE	

● SAFETY PRECAUTIONS ●

(Read these precautions before using.)

Before using this product, please read this manual and the relevant manuals carefully and pay full attention to safety to handle the product correctly. These precautions apply only to Mitsubishi equipment. Refer to the CPU module user's manual for a description of the PLC system safety precautions. In this manual, the safety precautions are classified into two levels:

" WARNING" and " CAUTION".



Indicates that incorrect handling may cause hazardous conditions, resulting in death or severe injury.



Indicates that incorrect handling may cause hazardous conditions, resulting in minor or moderate injury or property damage.

Under some circumstances, failure to observe the precautions given under " CAUTION" may lead to serious consequences.

Observe the precautions of both levels because they are important for personal and system safety.

Make sure that the end users read this manual and then keep the manual in a safe place for future reference.

[PRECAUTIONS FOR DESIGN]

CAUTION

- Do not bunch the control wires or communication cables with the main circuit or power wires, or install them close to each other. They should be installed 100mm (3.9inch) or more from each other. Not doing so could result in noise that may cause malfunction.

[INSTALLATION PRECAUTIONS]

CAUTION

- Use the PC in an environment that meets the general specifications contained in this manual. Using this PC in an environment outside the range of the general specifications could result in electric shock, fire, erroneous operation, and damage to or deterioration of the product.
- Install so that the pegs on the bottom of the module fit securely into the base unit peg holes. The module fixing screws must be tightened by the specified torque. Not installing the module correctly or tightening the screws to the terminal base could result in erroneous operation, damage, or pieces of the product falling.

[WIRING PRECAUTIONS]

CAUTION

- If there are high levels of noise, ground the AG terminal and FG terminal with Class D grounding (Class 3 grounding) or higher dedicated for the PLC. Failure to observe this could lead to malfunctioning.
- When wiring in the PLC, be sure that it is done correctly by checking the product's rated voltage and the terminal layout. Connecting a power supply that is different from the rating or incorrectly wiring the product could result in fire or damage.
- Tighten terminal screws to the specified torque.
If a terminal screw is not tightened to the specified torque, it the module may fall out, short circuit, or malfunction.
If a terminal screw is tightened excessively, exceeding the specified torque, the module may fall out, short circuit, or malfunction due to breakage of the screw or the module.
- Be careful not to let foreign matters such as sawdust or wire chips get inside the module. These may cause fires, failure or malfunction.

[STARTUP/MAINTENANCE PRECAUTIONS]

WARNING

- When power is on, do not touch the terminals.
Doing so can cause an electric shock or malfunction.
- Before starting cleaning or terminal screw retightening, always switch off the power externally in all phases.
Not switching the power off in all phases can cause a module failure or malfunction.

CAUTION

- Never disassemble or modify the module.
Failure to observe this could lead to trouble, malfunctioning, injuries or fires.
- Always turn the power OFF before installing or removing the module. Failure to observe this could lead to module faults or malfunctioning.
- Do not install/remove the terminal block more than 50 times after the first use of the product. (IEC 61131-2 compliant)

[PRECAUTIONS FOR DISPOSAL]



CAUTION

- Dispose of this product as industrial waste.

● 安全注意事项 ●

(使用之前请务必阅读)

在使用本产品之前，应仔细阅读本手册，同时在充分注意安全的前提下正确操作。
本注意事项仅记载与本产品有关的内容。关于可编程控制器系统方面的安全注意事项，请参阅 CPU 模块的用户手册。

在“安全注意事项”中，安全注意事项被分为“警告”和“注意”两个等级。



警告

表示错误操作可能造成危险后果，导致死亡或重伤事故。



注意

表示错误操作可能造成危险后果，导致中度伤害、轻伤或财产损失。

此外，根据情况不同，即使标注为“注意”的事项也有可能引发严重后果。这两个等级的注意事项记载的均为重要内容，请务必遵守。

请妥善保管本手册以备需要时取阅，并将本手册交给最终用户。

【设计注意事项】

注意

- 请勿将控制线及通信电缆与主电路及动力线等捆扎在一起或相互靠得太近。
应相距大约 100mm 以上距离。
因为噪声有可能导致误动作。

【安装注意事项】

注意

- 应在手册记载的一般规格环境下使用可编程控制器。
如果在一般规格范围以外的环境中使用可编程控制器，可能导致触电、火灾、误动作、产品损坏或性能劣化。
- 请将模块下部的固定用凸起部切实插入基板的固定孔后，以规定的扭矩拧紧模块安装螺栓。
如果模块未正确安装并以螺栓固定，有可能造成误动作、故障或掉落。

【配线注意事项】

注意

- 必须将 AG 端子及 FG 端子与可编程控制器的专用接地线连接（特别是噪音过多时）。否则有可能导致误动作。
- 进行可编程控制器配线作业时，应在确认产品的额定电压及端子排列的基础上正确进行操作。
如果连接了与额定值不符的电源或配线错误，可能导致火灾或故障。
- 应在规定的扭矩范围内拧紧端子螺栓。
如果端子螺栓拧得过松，有可能导致短路或误动作。
如果端子螺栓拧得过紧，有可能造成螺栓及模块破损从而导致掉落、短路或误动作。
- 应注意防止切屑及配线头等异物掉入模块内。
否则有可能导致火灾、故障或误动作。

【启动 / 维护注意事项】

警告

- 在通电状态下请勿触摸端子。否则可能导致误动作。
- 在清洁模块或重新紧固端子螺栓时，必须从外部将电源全部断开后再进行操作。
如果未全部断开，有可能导致模块故障或误动作。

注意

- 请勿拆解或改造各模块。
否则可能导致故障、误动作、人身伤害或火灾。
- 在拆装模块时，必须从外部将电源全部断开后再进行操作。
如果未全部断开，有可能导致模块故障或误动作。
- 产品投入使用后，端子排的拆装次数不应超过 50 次。（根据 IEC61131-2 规范）

【报废处理注意事项】

注意

- 本产品报废时，应当作工业废物处理。

● CONDITIONS OF USE FOR THE PRODUCT ●

- (1) Mitsubishi programmable controller ("the PRODUCT") shall be used in conditions;
- i) where any problem, fault or failure occurring in the PRODUCT, if any, shall not lead to any major or serious accident; and
 - ii) where the backup and fail-safe function are systematically or automatically provided outside of the PRODUCT for the case of any problem, fault or failure occurring in the PRODUCT.

- (2) The PRODUCT has been designed and manufactured for the purpose of being used in general industries.

MITSUBISHI SHALL HAVE NO RESPONSIBILITY OR LIABILITY (INCLUDING, BUT NOT LIMITED TO ANY AND ALL RESPONSIBILITY OR LIABILITY BASED ON CONTRACT, WARRANTY, TORT, PRODUCT LIABILITY) FOR ANY INJURY OR DEATH TO PERSONS OR LOSS OR DAMAGE TO PROPERTY CAUSED BY the PRODUCT THAT ARE OPERATED OR USED IN APPLICATION NOT INTENDED OR EXCLUDED BY INSTRUCTIONS, PRECAUTIONS, OR WARNING CONTAINED IN MITSUBISHI'S USER, INSTRUCTION AND/OR SAFETY MANUALS, TECHNICAL BULLETINS AND GUIDELINES FOR the PRODUCT.

("Prohibited Application")

Prohibited Applications include, but not limited to, the use of the PRODUCT in;

- Nuclear Power Plants and any other power plants operated by Power companies, and/or any other cases in which the public could be affected if any problem or fault occurs in the PRODUCT.
- Railway companies or Public service purposes, and/or any other cases in which establishment of a special quality assurance system is required by the Purchaser or End User.
- Aircraft or Aerospace, Medical applications, Train equipment, transport equipment such as Elevator and Escalator, Incineration and Fuel devices, Vehicles, Manned transportation, Equipment for Recreation and Amusement, and Safety devices, handling of Nuclear or Hazardous Materials or Chemicals, Mining and Drilling, and/or other applications where there is a significant risk of injury to the public or property.

Notwithstanding the above, restrictions Mitsubishi may in its sole discretion, authorize use of the PRODUCT in one or more of the Prohibited Applications, provided that the usage of the PRODUCT is limited only for the specific applications agreed to by Mitsubishi and provided further that no special quality assurance or fail-safe, redundant or other safety features which exceed the general specifications of the PRODUCTS are required. For details, please contact the Mitsubishi representative in your region.

About the Manuals

The following manuals are related to this product.
Refer to the following table, and procure these manuals as necessary.

Detailed Manual

Manual name	Manual No. (Model code)
A/D converter module type A1S64AD User's Manual	IB-66336

1. Outline

This manual explains the specifications and names of each part of the A1S64AD type analog/digital converter (hereinafter, A1S64AD) used in combination with the MELSEC-A Series PLC CPU module (hereinafter PLC CPU).

2. Performance Specifications

The performance specifications of the A1S64AD are shown below.

Item	Specifications			
Analog input	Voltage: -10 to 0 to +10VDC (input resistance 1M Ω) Current: -20 to 0 to +20mA (input resistance 250 Ω)			Select with the input terminals.
Digital input	16-bit coded binary	-4096 to +4095 when set to 1/4000 -8192 to +8191 when set to 1/8000 -12288 to +12287 when set to 1/12000		
Input/output characteristics *1	Analog input	Digital output value (At 5V/20mA gain, 0V/90mA offset)		
		1/4000	1/8000	1/12000
	+10V	+4000	+8000	+12000
	+5V or +20mA	+2000	+4000	+ 6000
	0V or 0mA	0	0	0
-5V or -20mA	-2000	-4000	-6000	
-10V	-4000	-8000	-12000	
Maximum resolution		1/4000	1/8000	1/12000
	Voltage input	2.5mV	1.25mV	0.83mV
	Current input	10 μ A	5 μ A	3.33 μ A
General accuracy *2	Within \pm 1%	\pm 40	\pm 80	\pm 120
Maximum conversion speed	20ms/channel			
Maximum absolute input	Voltage \pm 15V Current \pm 30mA *3			

Item	Specifications			
No. of analog input points	4 channels/module			
Isolation specifications	Specific isolated area	Isolation method	Dielectric withstand voltage	Insulation resistance
	Between input terminal and PLC power supply	Photocoupler isolation	500V AC for 1 minute	5MΩ or more (measured with a 500V DC insulation resistance tester)
	Between channels	Not isolated	-	-
No. of occupied input/output points	Special 32 points			
Connection terminal	20-point terminal block			
External power supply	Not required			
Applicable wire size	0.75 to 1.5mm ²			
Applicable crimp terminal	1.25-3, 1.25-YS3, V1.25-3, V1.25-YS3A			
Internal current consumption (5VDC)	0.4A			
Weight	0.25kg			

*1: The gain is set to 5V and the offset to 0V as the default.

*2: This is the accuracy in respect to the maximum digital output value. The maximum digital value is the maximum value of the selected resolution. It is the same for either a current input or voltage input.

*3: Current value indicates value of instant input current that does not break module inner electrical resistance.

Point
The range of the analog input at the which maximum resolution and general accuracy can be tolerated is as follows. Voltage -10 to 0 to +10V Current -20 to 0 to +20mA



Refer to the User's Manual for the PLC CPU in use for details on the general specifications.

3. Names and Settings of Each Part

3.1 Names of each part

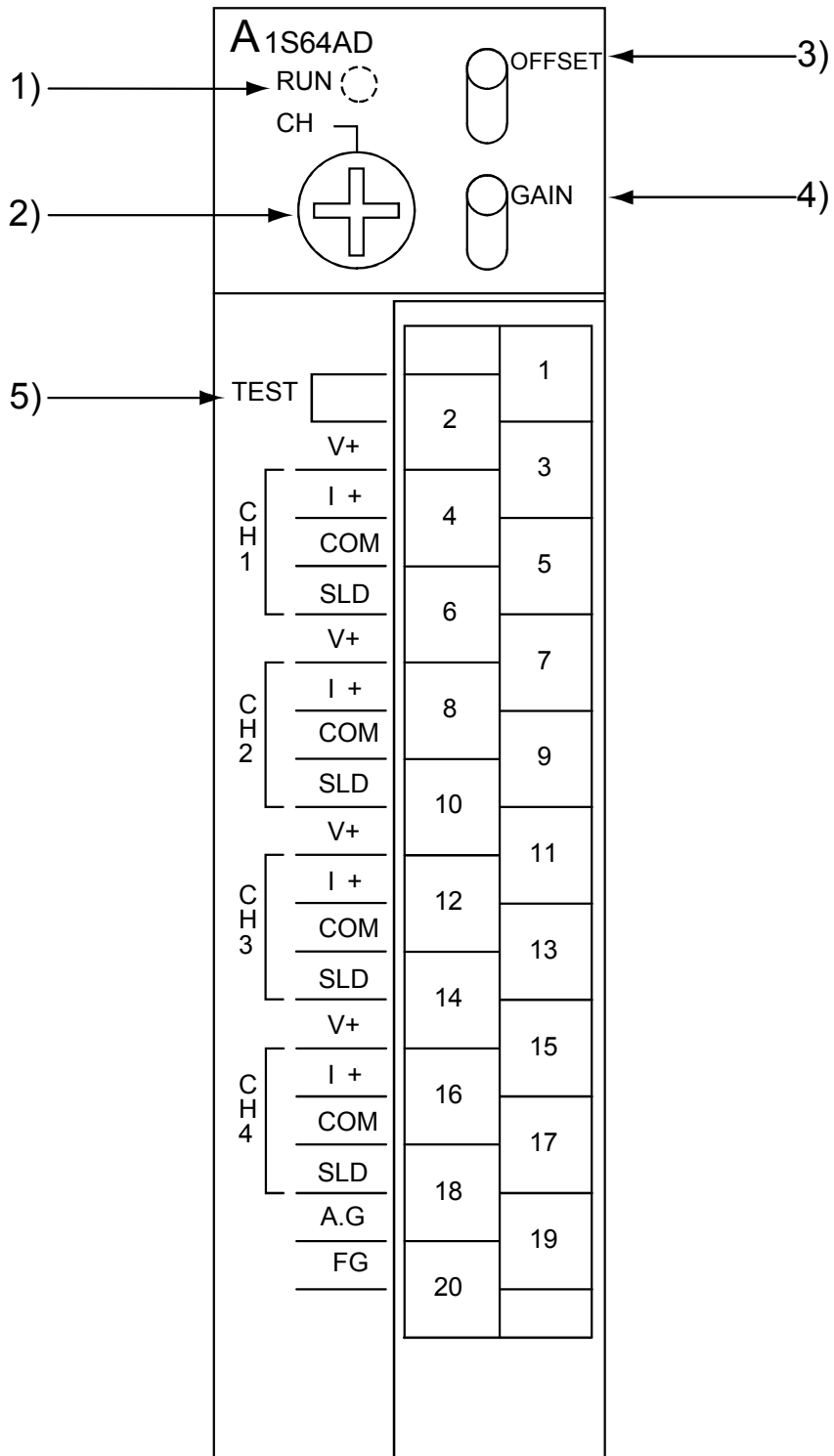
The names of each A1S64AD part are shown below.

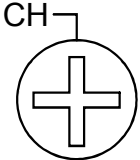
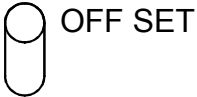

No.	Name	Details
1)	RUN LED 	The operation state of the A1S64AD is indicated. • Normal mode ON : In normal operation Flickering: Write data error has occurred. OFF : 5V power OFF or watch dog timer error • Test mode ON : OFF SET switch or GAIN switch is ON OFF : OFF SET switch and GAIN switch are both OFF
2)	CHANNEL selection switch 	The channel for adjusting the offset and the gain is selected. (Channels other than 1 to 4 have no process.)
3)	OFF SET switch 	By setting the switch to the OFF SET side, the analog input value at that time will be saved by the A1S64AD as the offset value.
4)	GAIN switch 	By setting the switch to the GAIN side, the analog input value at that time will be saved by the A1S64AD as the gain value.
5)	Test mode terminal 	Short-circuit across terminals 1 and 2 when setting the offset or gain.

3.2 Setting the offset and gain

Follow the procedure below to change the input/output conversion characteristics.

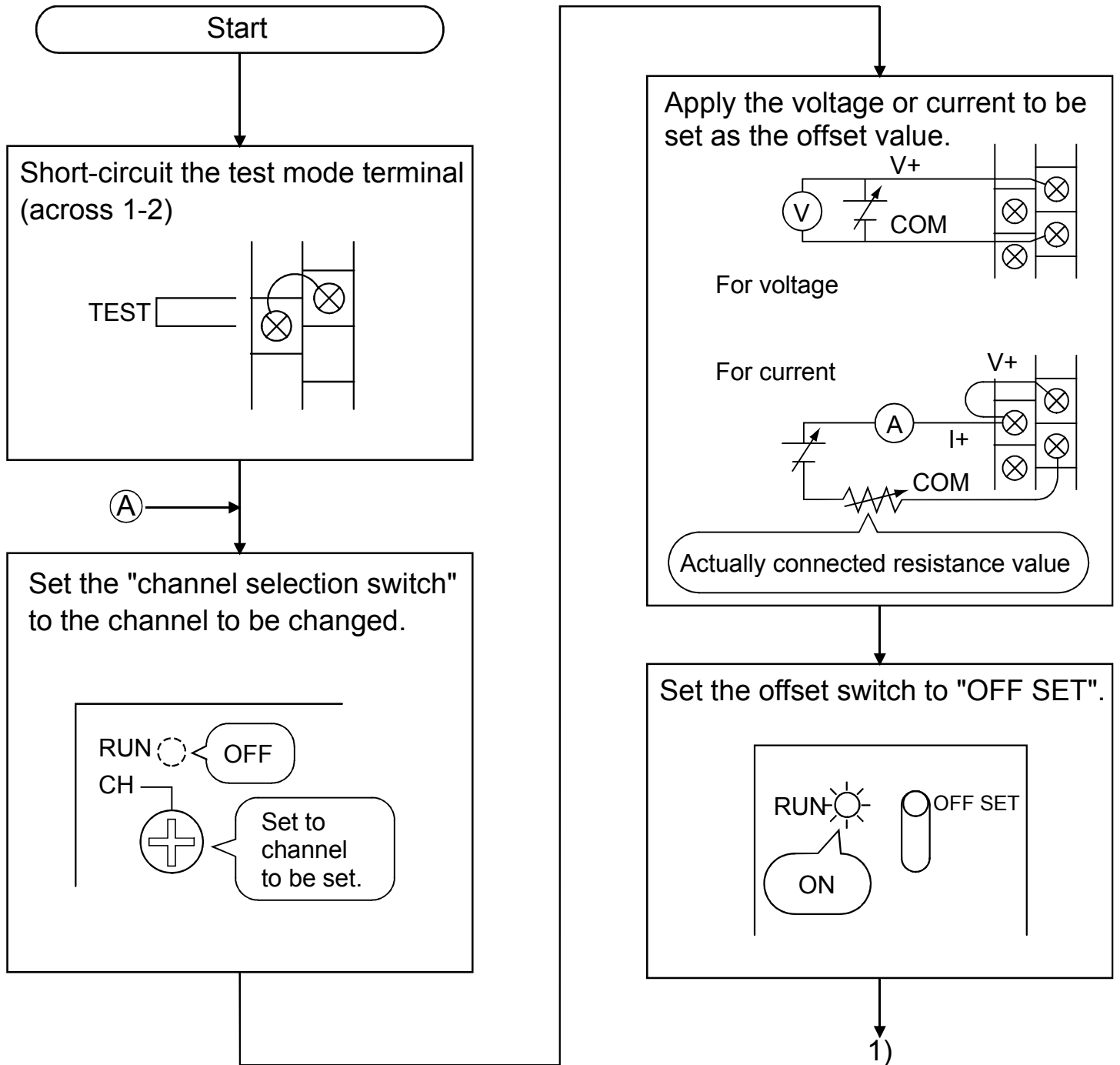

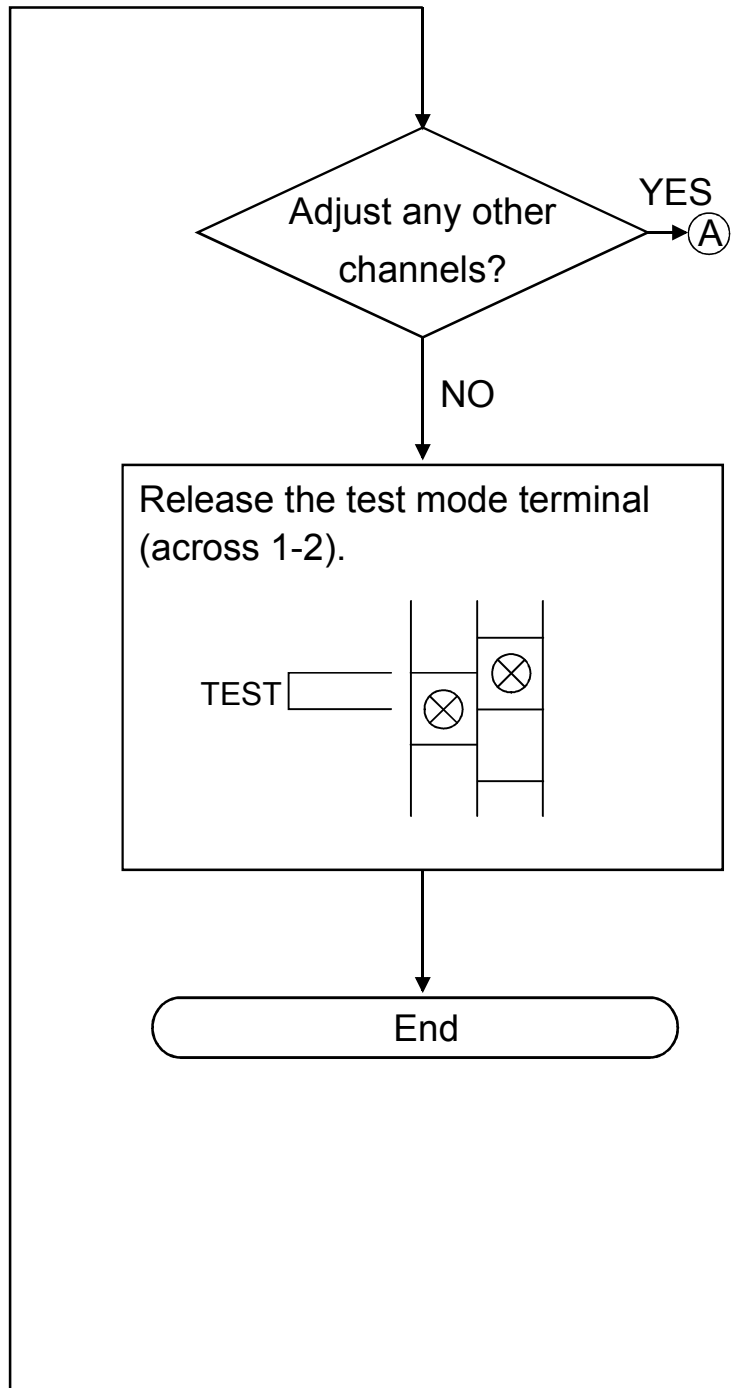
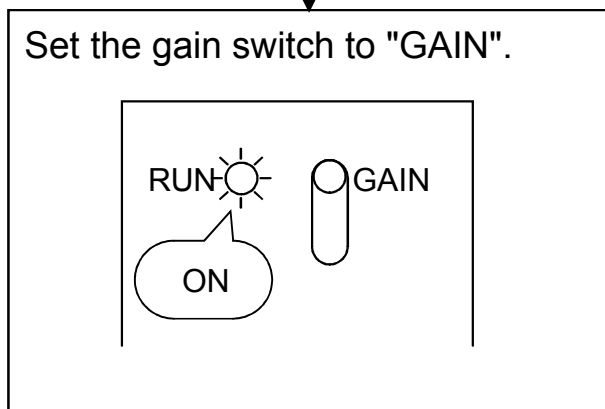
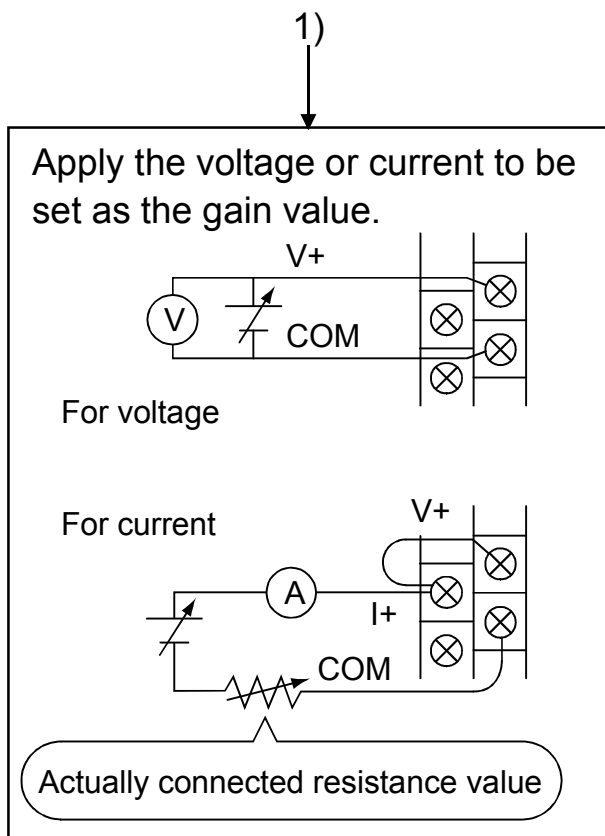

Remarks

The offset value and gain value have the following meanings.

- (1) The offset value is the analog input value (voltage or current) at which the digital output value is "0".
- (2) The gain value is the analog input value (voltage or current) at which the digital output value is the following:
 - (a) 2000 (1/4000 resolution)
 - (b) 4000 (1/8000 resolution)
 - (c) 6000 (1/12000 resolution)

4. Handling

4.1 Precautions for handling

- (1) The main body case and terminal block are made of resin, so do not drop them or apply strong impacts.
- (2) Do not remove the module PCB from the case. Doing so could lead to faults.
- (3) Make sure that foreign matter, such as wire scraps, does not enter from the top of the module during wiring. Remove any foreign matter that does enter.
- (4) Tighten the module installation screws and terminal screws within the following ranges.

Screw position	Tightening torque range
Module installation screw (M4 screw)	78 to 118N • cm
Terminal block terminal screw (M3.5 screw)	59 to 88N • cm
Terminal block installation screw (M4 screw)	78 to 118N • cm

5. Wiring

The precautions for wiring and an example of module connection are given in this section.

5.1 Precautions for wiring

External wiring that is not easily affected by noise is a prerequisite for using the A1S64AD functions to the fullest and creating a highly reliable system.

The precautions for external wiring are given below.

- (1) Use separate cables for the alternating current and A1S64AD external input signals to eliminate the effect of surge or inductance on the alternating current side.
- (2) Do not lay the wires or bundle the wires with the main circuit wires, high voltage wires or the load wire other than that from the PLC. Failure to observe this will increase the effect of noise, surge and inductance.
- (3) Ground the shield of a shielded wire or shielded cable to one point on the PLC side.

5.2 Example of module connection

An example for connecting the voltage input and current input is given below.

(1) For voltage input

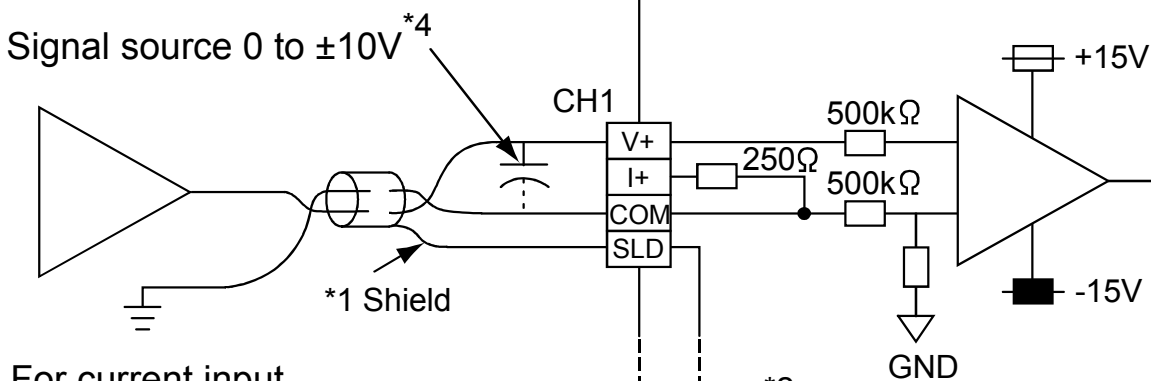

(2) For current input

Signal source 0 to $\pm 20mA$

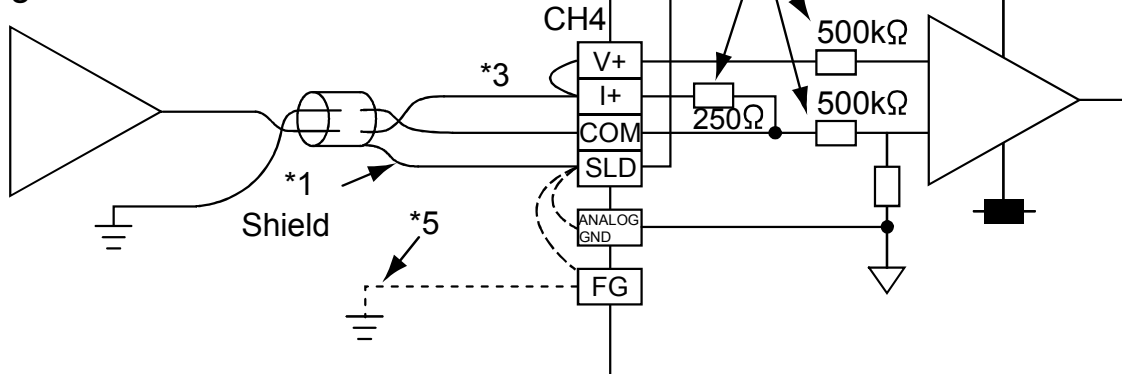

*1: Use a 2-core twisted shield wire.

*2: Indicates the A1S64AD input resistance.

*3: For the current input, always connect with the (V+) and (I+) terminals.

*4: If noise or ripple is generated in the external wiring, connect a 0.1 to 0.47 μF capacitor (approximate 25V or more withstand voltage) between the terminal V and COM.

*5: Ground if there are high levels of noise. There are cases when the power supply unit FG or this module FG should also be grounded.

When changing the grounding wiring (grounding or not grounding) after setting the offset value and gain value, set the offset value and gain value again.

6. Outline Dimension Drawing

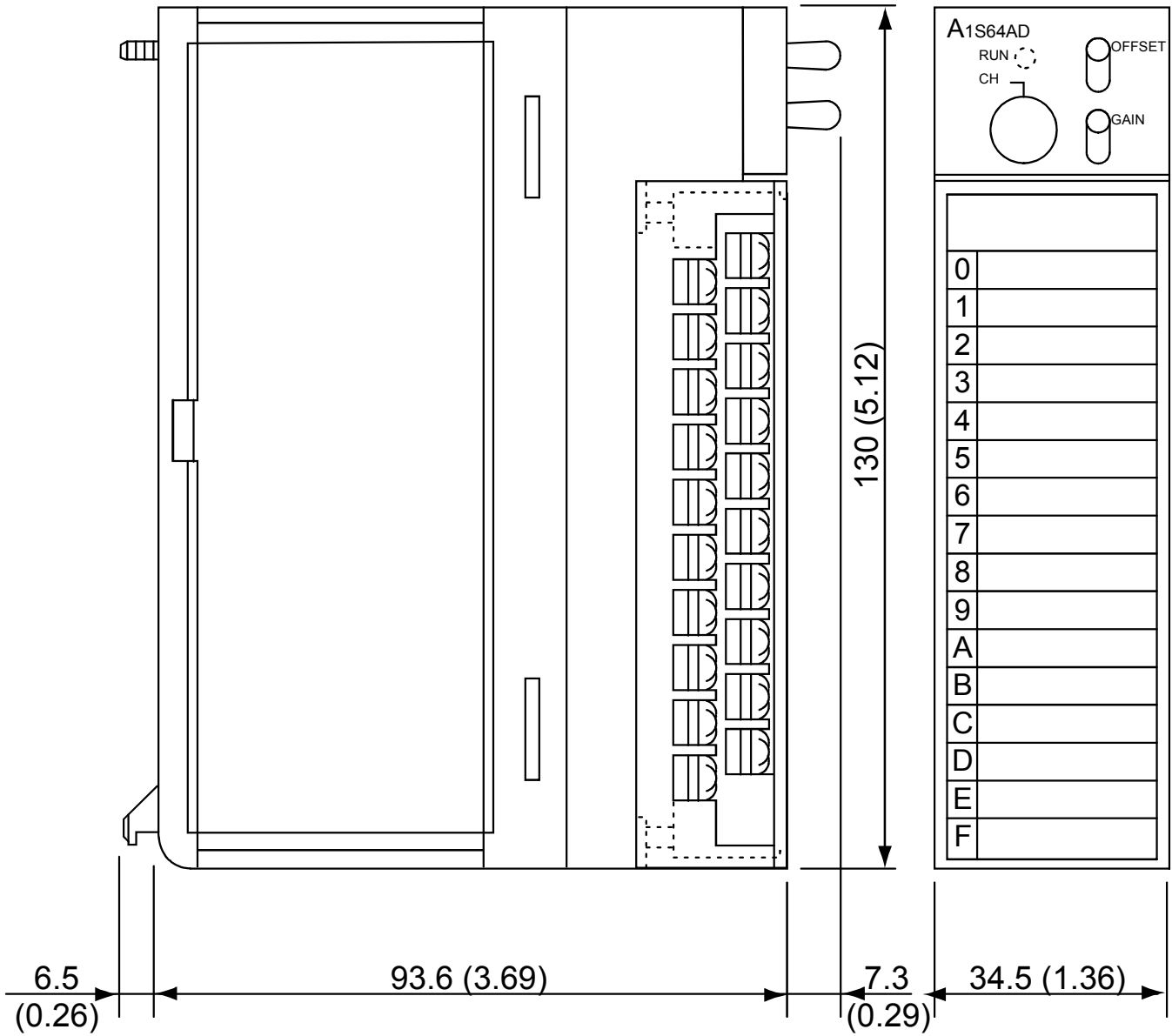

Unit:mm(in)

WARRANTY

Mitsubishi will not be held liable for damage caused by factors found not to be the cause of Mitsubishi; machine damage or lost profits caused by faults in the Mitsubishi products; damage, secondary damage, accident compensation caused by special factors unpredictable by Mitsubishi; damages to products other than Mitsubishi products; and to other duties.

Country/Region	Sales office/Tel	Country/Region	Sales office/Tel
U.S.A	Mitsubishi Electric Automation Inc. 500 Corporate Woods Parkway Vernon Hills, IL 60061, U.S.A. Tel : +1-847-478-2100	China	Mitsubishi Electric Automation (China) Ltd. 4/F Zhi Fu Plazz, No.80 Xin Chang Road, Shanghai 200003, China Tel : +86-21-6120-0808
Brazil	MELCO-TEC Rep. Com.e Assessoria Tecnica Ltda. Rua Correia Dias, 184, Edificio Paraiso Trade Center-8 andar Paraiso, Sao Paulo, SP Brazil Tel : +55-11-5908-8331	Taiwan	Setsuyo Enterprise Co., Ltd. 6F No.105 Wu-Kung 3rd.Rd, Wu-Ku Hsiang, Taipei Hsine, Taiwan Tel : +886-2-2299-2499
Germany	Mitsubishi Electric Europe B.V. German Branch Gothaer Strasse 8 D-40880 Ratingen, GERMANY Tel : +49-2102-486-0	Korea	Mitsubishi Electric Automation Korea Co., Ltd. 1480-6, Gayang-dong, Gangseo-ku Seoul 157-200, Korea Tel : +82-2-3660-9552
U.K	Mitsubishi Electric Europe B.V. UK Branch Travellers Lane, Hatfield, Hertfordshire., AL10 8XB, U.K. Tel : +44-1707-276100	Singapore	Mitsubishi Electric Asia Pte, Ltd. 307 Alexandra Road #05-01/02, Mitsubishi Electric Building, Singapore 159943 Tel : +65-6470-2480
Italy	Mitsubishi Electric Europe B.V. Italian Branch Centro Dir. Colleoni, Pal. Perseo-Ingr.2 Via Paracelso 12, I-20041 Agrate Brianza., Milano, Italy Tel : +39-039-60531	Thailand	Mitsubishi Electric Automation (Thailand) Co., Ltd. Bang-Chan Industrial Estate No.111 Moo 4, Serithai Rd, T.Kannayao, A.Kannayao, Bangkok 10230 Thailand Tel : +66-2-517-1326
Spain	Mitsubishi Electric Europe B.V. Spanish Branch Carretera de Rubi 76-80, E-08190 Sant Cugat del Valles, Barcelona, Spain Tel : +34-93-565-3131	Indonesia	P.T. Autoteknindo Sumber Makmur Muara Karang Selatan, Block A/Utara No.1 Kav. No.11 Kawasan Industri Pergudangan Jakarta - Utara 14440, P.O.Box 5045 Jakarta, 11050 Indonesia Tel : +62-21-6630833
France	Mitsubishi Electric Europe B.V. French Branch 25, Boulevard des Bouvets, F-92741 Nanterre Cedex, France Tel : +33-1-5568-5568	India	Messung Systems Pvt, Ltd. Electronic Sadan NO:III Unit No15, M.I.D.C Bhosari, Pune-411026, India Tel : +91-20-2712-3130
South Africa	Circuit Breaker Industries Ltd. Private Bag 2016, ZA-1600 Isando, South Africa Tel : +27-11-928-2000	Australia	Mitsubishi Electric Australia Pty. Ltd. 348 Victoria Road, Rydalmere, N.S.W 2116, Australia Tel : +61-2-9684-7777

MITSUBISHI ELECTRIC CORPORATION

HEAD OFFICE : TOKYO BUILDING, 2-7-3 MARUNOUCHI, CHIYODA-KU, TOKYO 100-8310, JAPAN
NAGOYA WORKS : 1-14, YADA-MINAMI 5-CHOME, HIGASHI-KU, NAGOYA, JAPAN

When exported from Japan, this manual does not require application to the Ministry of Economy, Trade and Industry for service transaction permission.

Specifications subject to change without notice.